



Automatic Passenger Counting

IRMA 6 R2

Product Data Sheet

IRMA6-R2-SENSOR-HD-00-...[-IO]-00[-R]

iris INTELLIGENT
SENSING

www.iris-sensing.com

Table of content

- 1 Product 3
- 1.1 Brief description 3
- 1.2 Product variants 3
- 1.2.1 List of available IRMA 6 R2 models 4
- 1.3 Components 5
- 1.3.1 Sensor unit 5
- 1.3.2 Interface unit with M12 connectors 6
- 1.3.3 Interface unit with RJ45 connector 7
- 2 Technical Data 8
- 2.1 Field of view 8
- 2.2 General Data 9
- 2.3 Weight and dimensions 10
- 2.3.1 IRMA 6 with interface unit RJ54 10
- 2.3.2 IRMA 6 with interface unit ETH or POE 11
- 2.4 Power supply 12
- 2.5 Door signal input 12
- 3 Security features 13
- 4 Communication protocols 13
- 5 Compliance with regulations and standards 14
- 5.1 General 14
- 5.1.1 Additional type tests 14
- 5.2 Automotive application 14
- 5.3 Railway application 15
- 5.3.1 Tests according to EN 50155:2021 15

Contact information

iris-GmbH infrared & intelligent sensors

Schnellerstrasse 1–5 Phone: +49 30 5858 14-0
 12439 Berlin Web: www.iris-sensing.com
 Germany

Disclaimer

The information contained in the documentation of IRMA 6 is based on product data resulting from the development and approval phases as well as the production and field experience. These documents do not claim to be error-free and will be updated or corrected. Such modifications may be made by iris-GmbH infrared & intelligent sensors (hereafter only “iris-GmbH”) without prior notice.

Customers of iris-GmbH are permitted to use the documentation or parts of it to create their own documents for the purpose of documenting the use of the product in their environment of use or project. iris-GmbH is not responsible for the correctness, completeness, or usability of such documents. Such documents are the sole responsibility of the creator.

iris-GmbH recommends to always keep a complete set of documentation and software as described in the *IRMA 6 System Overview* document available, and to update this documentation and software regularly. iris-GmbH informs its customers and sales partners about updated or corrected documents and software/firmware as soon as they are available. iris-GmbH assumes no responsibility for documentations or software that are incomplete or outdated.

As part of the complete set as aforementioned, iris-GmbH provides firmware updates, which may include security updates. It is the sole responsibility of the users, owners or service providers to regularly update the software of the sensors to avoid compromising sensors or network. iris-GmbH assumes no responsibility for security gaps and resulting issues if these were made possible by the use of outdated software or firmware, regardless of whether it has not been updated or has been downgraded.

It is not permitted to make the Software or documentation, parts thereof, or documents that contain information taken from the documentation available to third parties without prior written consent from iris.

1 Product

1.1 Brief description

The IRMA 6 is an automatic passenger counting sensor working with 76.800 pixel ToF (Time-of-Flight)-technology. It is designed for vehicle and railway applications, and is mounted above doors.

IRMA 6 generates real-time counting data for further processing via Ethernet to on-board computer.

1.2 Product variants

IRMA 6 is available in 3 basic variants.

Models with M12-Connectors for Ethernet, power supply, and IO

ETH variant: The interface is designed to be connected to an Ethernet installation via a switch or router. The sensor needs a power supply, typical 24 V from the vehicles on-board power supply.

POE variant: With PoE (Power over Ethernet), electrical power is supplied via the Ethernet cable, 48 V typical. A separate power supply is not needed.

All variants are available with an additional IO connector for door contact (IO-Option).

All sensor variants with M12 connector are available in versions complying with the different regulations for railway or automotive (bus, car) applications.

Model with RJ45 Connector for Ethernet and single wire connection for power supply and IO

RJ45 variant: The interface is designed to be connected to an Ethernet installation via a switch or router. The sensor needs a power supply, typical 24 V.

The RJ45-Variant is designed for use in automotive or stationary applications. Due to the use of standard RJ45 cables, the resistance of the interfaces to mechanical or environmental loads, such as vibration or humidity, is limited.

1.2.1 List of available IRMA 6 R2 models

Product variant	Product name	Item number	Area of use	Description
IRMA 6 ETH	IRMA6-R2-SENSOR-HD-00-ETH-IO-00-R	5301_06	Railway	Ethernet variant, with IO-Option, railway application
	IRMA6-R2-SENSOR-HD-00-ETH-00-R	5301_07		Ethernet variant, railway application
IRMA 6 POE	IRMA6-R2-SENSOR-HD-00-POE-IO-00-R	5301_08		POE variant, with IO-Option; railway application
	IRMA6-R2-SENSOR-HD-00-POE-00-R	5301_09		POE variant, railway application
IRMA 6 ETH	IRMA6-R2-SENSOR-HD-00-ETH-IO-00	5301_00	Automotive	Ethernet variant, with IO-option, automotive application
	IRMA6-R2-SENSOR-HD-00-ETH-00	5301_01		Ethernet variant, automotive application
IRMA 6 POE	IRMA6-R2-SENSOR-HD-00-POE-IO-00	5301_02		POE variant, with IO-option, automotive application
	IRMA6-R2-SENSOR-HD-00-POE-00	5301_03		POE variant, automotive application
IRMA 6 RJ45	IRMA6-R2-SENSOR-HD-00-RJ45-IO-00	5301_12		RJ45 variant, with IO-option, automotive application

1.3 Components

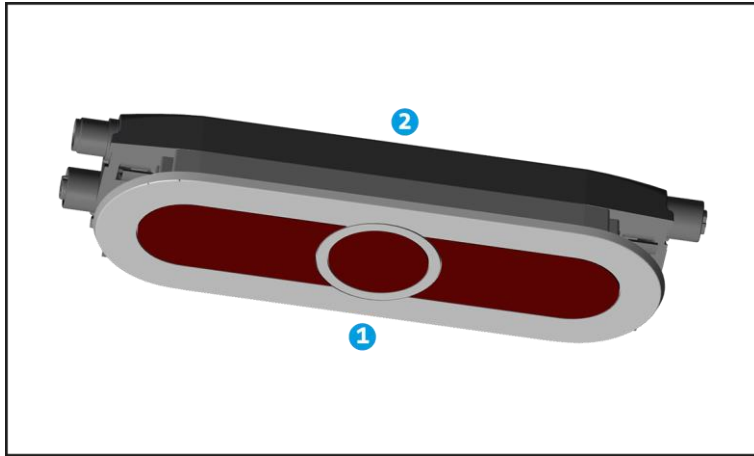

IRMA 6 consists of a sensor unit and an interface unit.

- 1 Sensor unit
- 2 Interface unit

1.3.1 Sensor unit



- 1 Functional sensor face – behind the protective windows laser emitter and time of flight sensors are located.
- 2 Sealing between sensor unit and interface unit.
- 3 Connector to interface unit
- 4 Labels

1.3.2 Interface unit with M12 connectors

The interface unit connects the sensor to the network and power supply. As an option, IO-Signals may be connected.

The picture shows the ETH variant of the interface unit with IO option. The other variants look similar, except they have less connectors.

- 1 Power supply connector (at ETH variant)
- 2 IO connector (optional)
- 4 Ethernet connector

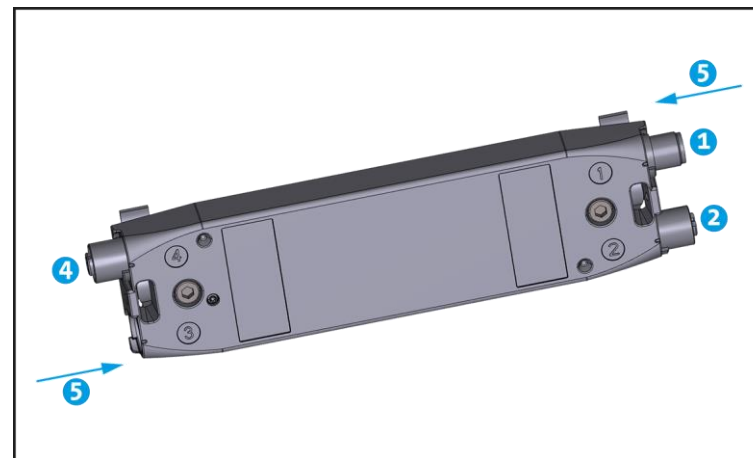

Connection table

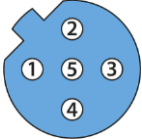
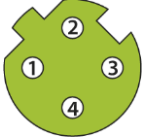
No.	Function	Variant: ETH	POE	Connector type ¹	PIN assignment:				
					1	2	3	4	5
1	Power supply	X	n/a	M12 contact pins A-coded					
2	GPIO (IO option)	o	o	M12 contact sleeves B-coded					
4	Ethernet	X	X	M12 contact sleeves D-coded					

PIN assignment:
 1 VP+ 2 VP- 3 n/c
 1 Door signal + 2 Door signal - 3 Door clear + 4 Door clear - 5 n/c
 The door signal input is bipolar, the polarity does not have to be observed, cp. 2.5 Door signal input, p. 12.
 1 TD+ (DC+)² 2 RD+ (DC-)² 3 TD- (DC+)² 4 RD- (DC-)²

X = existing; o = optional; n/a = not applicable; n/c = not connected

- 1 Viewing direction on connectors: See arrows 5 in image.
- 2 POE variant only, according to IEEE 802.3af: Type 1, Class 0, Mode A

1.3.3 Interface unit with RJ45 connector

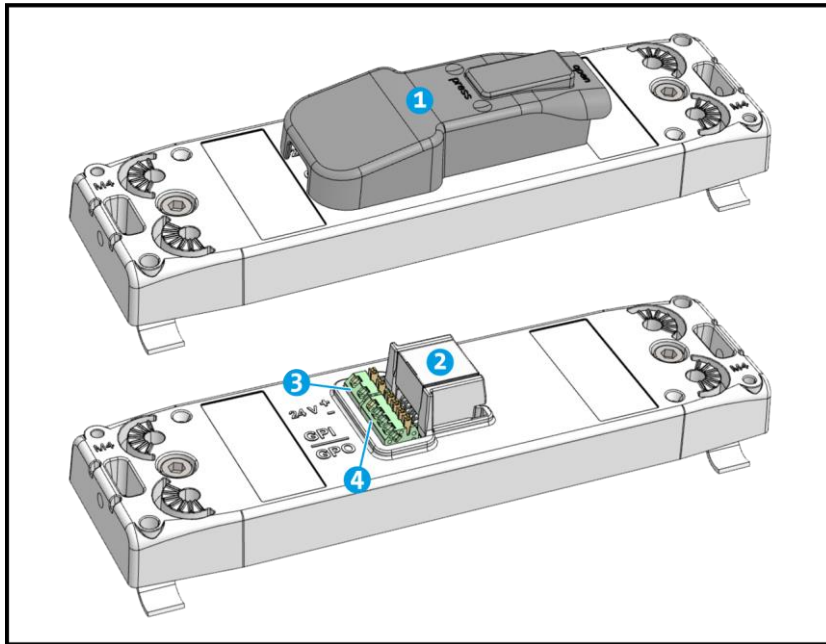

- ❶ Protective cap (option, increases the protection class to IP41)
- ❷ RJ45 Ethernet connector
- ❸ Spring terminal for single wire power supply connection
- ❹ Spring terminal for single wire IO connection (optional)

Connection table

Function	Connector type		PIN / contact assignment
Power supply	Terminal		+ VP+ - VP-
IO option	Terminal		GPI ¹ Door signal + Door signal - GPO ¹ Door clear + Door clear -
Ethernet	RJ45 jack		1 TD+ 2 TD- 3 RD+ 6 RD-

¹ IO connections (GPI, GPO) are bipolar, the polarity does not have to be observed, cp. [2.5 Door signal input, p. 12](#).

2 Technical Data

2.1 Field of view

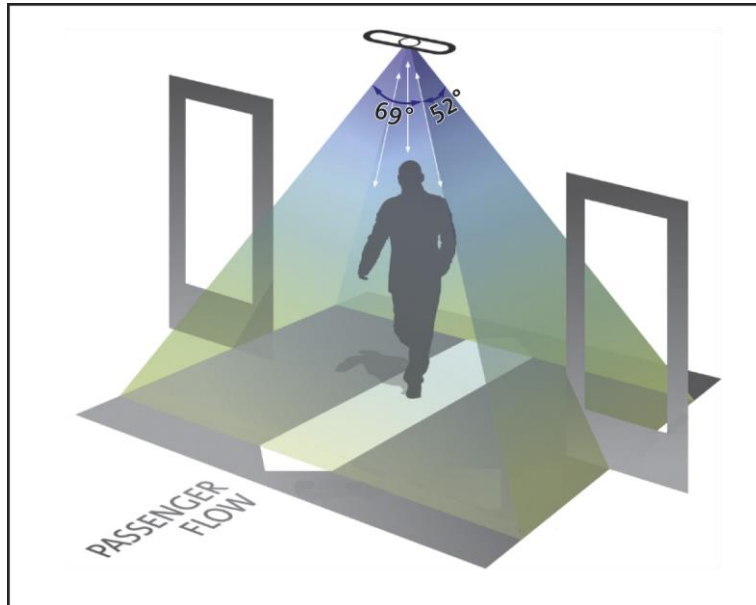

The field of view is determined by the aperture angles of the time-of-flight sensor. With aperture angles of 69° (in the direction of the door width) and 52° (in the direction of passenger movement), the covered door width results from the mounting height of the sensor, as shown in the table.

The field of illumination is determined by the aperture angles of the infrared light emitted by the sensor.

For reliable illumination of the field of view, the field of illumination is designed to be somewhat larger.

Parameter	Value	Note
Field of view	69° x 52°	FOV
Field of Illumination	86° x 68°	FOI
Mounting height	1.80 m to 2.50 m	Passengers need to be able to walk upright below the sensor to ensure accurate counting.

Mounting height	Maximal covered door width
1,800 mm	1,250 mm
1,900 mm	1,400 mm
2,000 mm	1,550 mm
2,100 mm	1,700 mm
2,200 mm	1,850 mm
2,300 mm	2,000 mm
2,400 mm	2,150 mm
2,500 mm	2,300 mm

The above values are **standard values**. In most cases wider ranges can be covered.

For further support, please contact iris customer support:

<https://www.iris-sensing.com/support/>

2.2 General Data

Parameter	Value	Note
Resolution	320 x 240 px	
Housing material	Aluminium die cast	
Material of optical openings	Polycarbonate	
Color coding of sensor	RAL 9005	Sensor front outer surface with pearl structure
Inner cover	Glass fibre reinforced plastic	Covers between sensor unit and interface unit
Ambient conditions		
Operating temperature range (TB)	-25 °C (-13 °F) to +70 °C (158 °F)	According to EN 50155:2021, OT3
Temperature range for transport, storage	-40 °C (-40 °F) to +85 °C (185 °F)	
Relative humidity	max. 95 %	
Protection class of housing (M12 variants)	IP65	when mounted, according to IEC 60529:1989+A1:1999+A2:2013
Protection class of housing (RJ45 variant)	IP41	with protective cap
	IP20	without protective cap
IK protection class	IK06	according to EN 50102:1995
Illumination		
Laser class	1	according to IEC 60825-1:2014, for normal operation, set-up, maintenance
Wavelength	850 nm	
Required scene illumination	None	
Mean Time Between Failures (MTBF)	1.24 x 10 ⁶ h	Condition: 25 °C, 77 °F
Ethernet	max. 100 Mbit/s	according to IEEE 802.3 For POE variant: according to IEEE 802.3af, Type 1, Class 0 (12.95 W), Mode A

2.3 Weight and dimensions

Parameter	ETH variant	POE variant	RJ45-variant	
			w/o cap	with cap
Weight sensor unit [g]	280 ±2 %	280 ±2 %	280 ±2 %	280 ±2 %
Weight interface unit [g]	205 ±2 %	191 ±2 %	n/a	
Weight total [g]	485 ±2 %	471 ±2 %	n/a	
Weight interface unit with IO option [g]	221 ±2 %	207 ±2 %	193 ±2 %	205 ±2 %
Weight total with IO option [g]	501 ±2 %	487 ±2 %	473 ±2 %	485 ±2 %
Length x Width x Height [mm x mm x mm]	211±2 x 62 x 32,3	201.2±2 x 62 x 32,3		n/a
Length x Width x Height, with IO option [mm x mm x mm]		211±2 x 62 x 32,3	192 x 62 x 46.7	192 x 62 x 50.2

The following sketches show the dimensions of IRMA 6

2.3.1 IRMA 6 with interface unit RJ54

Height above the panel

Dimension X in the side view is the thickness of the interface unit behind the material, where IRMA 6 is mounted.

It calculates as $X = \text{“height of sensor – 3.8 mm”} - \text{“thickness of panel”}$.

- ❶ RJ45 variant without protective cap
- ❷ RJ45 variant with protective cap (approx.)

Length x Width

- ❸ Length x width (mm) of the RJ45 interface unit
- ❹ Sensor unit mounted with interface unit
- ❺ Length x width of the complete sensor is the length x width of the sensor unit ❺, 192 mm x 62 mm.

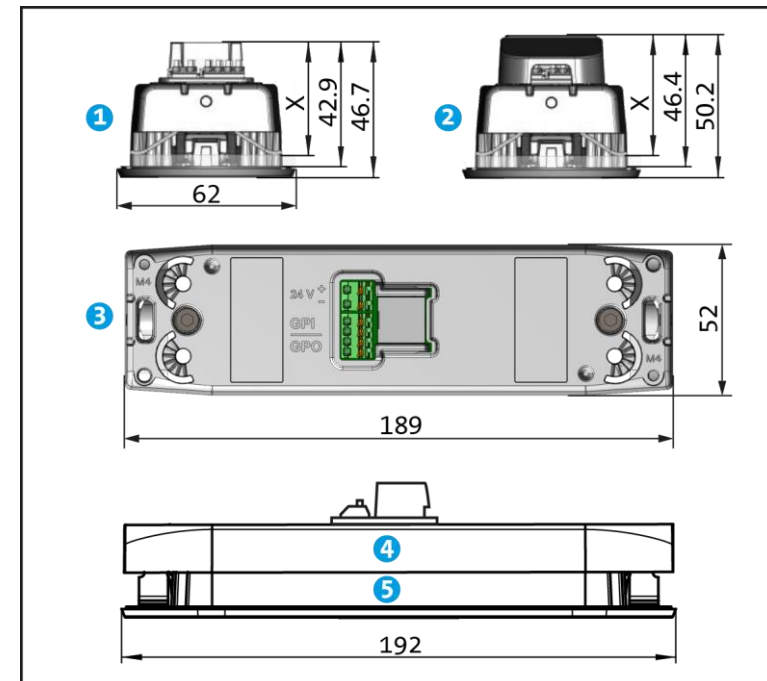

2.3.2 IRMA 6 with interface unit ETH or POE

Height above the panel

Dimension X in the side view **5** is the thickness of the interface unit behind the material, where IRMA 6 is mounted.

It calculates as $X = \text{“height of sensor”} - \text{“thickness of panel”}$.

Example: If IRMA 6 **5** with M12 connectors is mounted at a panel with a thickness of 4 mm, than X is 28.5 mm - 4 mm = 24.5 mm.

Mind that there also must be space to tighten the 2 M5x20 screws **10** that fix the interface unit **6** to the sensor unit **7**.

Length x Width

The view “A” shows an ETH variant with IO option (. This is the only variant with 3 M12-connectors (**1**, **2**, **4**).

View “B” shows a POE variant without the IO option. This is the only M12 variant without connectors on the “left” end. It only needs 1 M12 connector **4**.

For all ETH variants and for the POE variant with IO option the length of the complete sensor is the length of the Interface unit **6**, 211±2 mm.

For the POE variant without IO option the length of the complete sensor (201.2±2 mm) is determined by the combination of sensor unit **7** and interface unit.

The width of all complete sensors is the width of the sensor unit, 62 mm

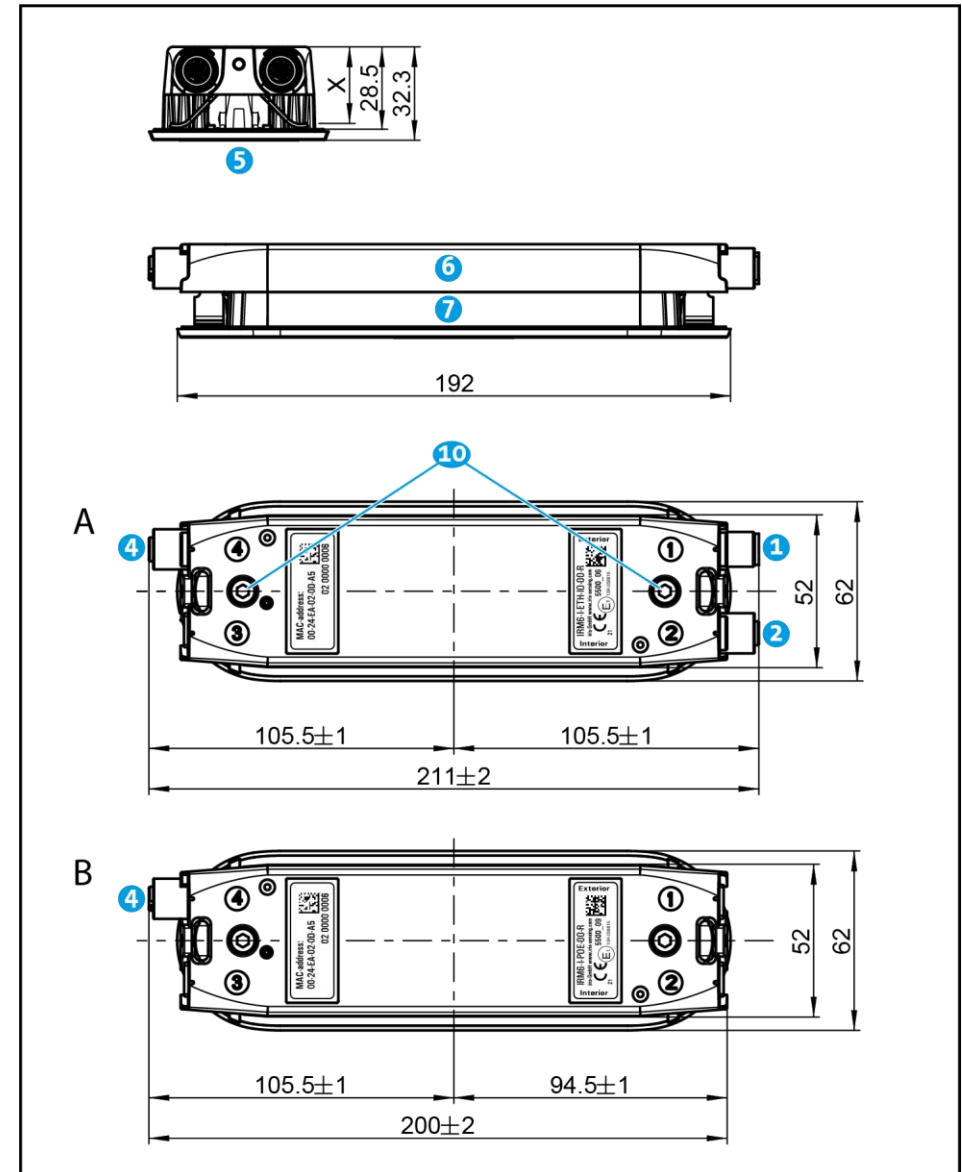

2.4 Power supply

Parameter		Value for variant:			Note
		ETH	POE	RJ45	
Power supply voltage	min.	16 V	n/s	16 V	POE variant: Power over Ethernet according to IEEE 802.3af: Type 1, Class 0 (12.95 W), Mode A (power over data lines)
	max.	57 V	57 V	32 V	
	typical	24 V	48 V	24 V	
Power consumption	P_{avg} , counting inactive	3 W	3 W	3 W	Ambient temperature 25 °C, 77 °F
	P_{avg} , counting active ¹	5 W	5 W ($V_{POE} = 54$ V)	5 W	For ETH and RJ45 variants:
	P_{avg_max} , counting inactive	3.5 W		3.5 W	<ul style="list-style-type: none"> Supply Voltage 24 V Max. duration of P_{Peak}: 1.37 ms
	P_{avg_max} , counting active ¹	7 W	6 W ($V_{POE} = 48$ V)	7 W	
	P_{Peak} , counting inactive	13 W		13 W	
	P_{Peak} , counting active ¹	30 W	15.4 W ²	30 W	

¹ Active mode: Counting active. Sensor is in operation mode and algorithms are running.

² When planning the energy budget of the POE switch, its power supply has to deliver peak power according to IEEE 802.3af (15.4 W), taking into account compensation of cable losses of up to 2.45 W.

2.5 Door signal input

Parameter	Value	Note
Input		Bipolar (+/-)
Input level low	-6 V to +6 V	
Input level high	-60 V to -9V, +9 V to +60 V	Protection limit: 60 V
Switching frequency	20 Hz	
Galvanical insulation against I/O	60 V	
Current (24 V _{Supply})	8 mA	R _{in} : 2,800 Ω
Galvanical insulation against V _{Supply} and chassis ground	500 V _{AC}	

3 Security features

Sabotage detection

As the sensors are used in an environment with public access and must have a free field of view it is not possible to fully protect the surface against damage. The sensor detects and reports damages of the surface that are critical to the function.

Cybersecurity features

Configuration, updating, and communication of the sensor and its software is protected by cybersecurity measures.

- User authentication management.
- Role-based access management.
- Certificate management.
- Secure update procedure.

4 Communication protocols

Network communication protocols

For network communication the following protocols are available: DHCP, HTTP, HTTPS, MQTT, SNMP, mDNS, DNS-SD, TCP/IP UDP

Application communication protocols

The table lists the available communication protocols for the APC application.

Protocol	Brief description
UIP^{RETROFIT}	UIP ^{RETROFIT} is a minimal implementation of IRMA MATRIX legacy protocol UIP for use in retrofit projects. All functionalities of UIP are implemented except image streaming and parameter/firmware update. For parameter settings and firmware updates the IRMA 6 web interface or web API can be used.
IBIS-IP	<p>IBIS-IP (VDV 301) standard provides an IP-based service-oriented successor standard for the IBIS Wagenbus defined in VDV 300. IRMA 6 sensors implement Passenger Counting, Device Management and Door State services. The communication is managed via HTTP XML-formatted messages.</p> <p>IBIS-IP is recommended for following market regions: Germany, Austria, Switzerland.</p> <p>Please refer to the VDV association website for specifications: https://www.vdv.de/ip-kom-oev.aspx</p>
ITxPT	<p>ITxPT is a European standard defining a service-oriented IT architecture for public transportation. IRMA 6 sensors implement the APC service and Module Inventory service and are able to interact with other services of the vehicle communication architecture, such as the Time or VehicleToIP services.</p> <p>Two profiles are available:</p> <ol style="list-style-type: none"> 1 The in-vehicle profile where communication is managed via HTTP XML-formatted messages within the vehicle’s IP network. 2 The over-the-air profile, where the counting data is pushed via MQTT. <p>Please refer to the ITxPT website for specifications: https://itxpt.org/technology/itxpt-specifications/</p>
QIP	The QIP or Quick Integration Protocol is the default IRMA 6 communication protocol. It is a simple HTTP-based protocol offering required functions for operating the sensor. It is recommended for all projects that do not require ITxPT or IBIS-IP. Data is exchanged in XML format and offers different levels of compliance with ITxPT.

5 Compliance with regulations and standards

The following tables list standards and regulations, that are applied on IRMA 6 R2.

5.1 General

Regulation	Note
2014/30/EU	European directive relating to electromagnetic compatibility
2011/65/EU 2015/863/EU	European directive on the restriction of the use of hazardous substances in electrical and electronic components and equipment (RoHS)
2006/25/EC	European directive on the minimum health and safety requirements regarding the exposure of workers to risks arising from physical agents (artificial optical radiation)
Regulation (EC) No 1907/2006	European Regulation concerning the Registration, Evaluation, Authorisation and Restriction of Chemicals (REACH)
Regulation (EC) No 1272/2008	European Regulation on classification, labelling and packaging of substances and mixtures (CLP)

Standard	Note
IEC 60529:1989+A1:1999+A2:2013 EN 60529:1991+A1:2000+A2:2013	Degrees of protection provided by enclosures (IP code)
IEC 60825-1:2014	Safety of laser products - Part 1: Equipment classification and requirements

5.1.1 Additional type tests

Additional type tests	Test specification	Limit/Class
Testing storage at dry heat	IEC 60068-2-2:2007 (Bb)	+85 °C
Testing of impact resistance	EN 50102:1995	IK06

5.2 Automotive application

Regulation	Note
UN/ECE-R 118	Regulation No 118 of the Economic Commission for Europe of the United Nations (UN/ECE) — Uniform technical prescriptions concerning the burning behaviour of materials used in the interior construction of certain categories of motor vehicles
UN/ECE R 10	Regulation No 10 of the Economic Commission for Europe of the United Nations (UN/ECE) — Uniform provisions concerning the approval of vehicles with regard to electromagnetic compatibility

Standard	Note	Limit
IEC 60721-3-5:1997 EN 60721-3-5:1997	Classification of environmental conditions – Part 3: Classification of groups of environmental parameters and their severities; Section 5: Ground vehicle installations"	Tab. 6, cl. 5M3

5.3 Railway application

Standard	Note
EN 50155:2021	Railway Applications – Rolling Stock – Electronic equipment
EN 45545-2:2020	Railway applications - Fire protection on railway vehicles - Part 2: Requirements for fire behavior of materials and components
IEC 61373:2010 EN 61373:2010	Railway applications - Rolling stock equipment - Shock and vibration tests
IEC 60721-3-5:1997 EN 60721-3-5:1997	Classification of environmental conditions – Part 3: Classification of groups of environmental parameters and their severities; Section 5: Ground vehicle installations"
EN 50121-3-2:2016 + A1:2019	Railway applications – Electromagnetic compatibility – Part 3-2: Rolling stock – Apparatus
AK EMV Regulation No. EMV 06 of 09.05.2019	Radio compatibility of rail vehicles with railroad radio services (Technical regulation of the “Eisenbahnbundesamt”, the german supervising and approval authority for public railroads)

5.3.1 Tests according to EN 50155:2021

Requirements from EN 50155:2021	Test specification	Limit/Class
13.4.1	Visual inspection	– n. a.
13.4.2	Testing of the operating behavior	– n. a.
13.4.3	Testing of DC power supply	– 24 V S2 C1

Requirements from EN 50155:2021	Test specification	Limit/Class
13.4.4	Testing at low temperature	IEC 60068-2-1:2007 (Ad) OT3 (-25 °C)
13.4.5	Testing at dry heat	IEC 60068-2-2:2007 (Be) OT3/ST1 (+85 °C)
13.4.6	Testing storage at low temperature	IEC 60068-2-1:2007 (Ab) -40 °C
13.4.7	Insulation test	– > 20 MΩ (at 500 V _{DC})
13.4.8	Testing with cyclic damp heat	EN 60068-2-30:2005 (Db) +25 to +55 °C at 95 %rh
13.4.9	Testing of electromagnetic compatibility	EN 50121-3-2:2016+A1:2019 n. a.
13.4.10	Vibration and shock test	IEC 61373:2010 Pt. 8-10 + IEC 60721-3-5 class B, cat. 1 + Tab. 6, cl. 5M3
13.4.10.5	Testing the protection class of the housing (IP-Code)	IEC 60529:1989+A1:1999 +A2:2013 IP65
13.4.11	Equipment stress screening	IEC 60068-2-64:2008 +A1:2019 + IEC 60068-2-2:2007 n. a.
13.4.12	Testing rapid temperature changes	IEC 60068-2-14:2009 n. a.
13.4.13	Salt mist test	IEC 60068-2-11:2021 (Ka) n. a.
11.4	Requirements for fire behavior	EN 45545-2:2020 HL3